

# SAFETY ALERT

## STORAGE AND HANDLING OF GLASS SHEETS

This safety alert is published following the fatality of a worker who suffered horrific injuries while unpacking sheets of glass from a timber crate, which was stored on an A-frame. The storage and handling of glass sheets constitutes a high-risk activity that has the potential to cause serious injuries.

### OCCUPATIONAL HEALTH AND SAFETY REQUIREMENTS

Occupational health and safety legislation requires employers to ensure that control measures are in place to eliminate or minimise the risk of persons being injured – eg being hit by falling sheets of glass. Controls should include a safe system of work to ensure that glass sheets are properly stored and restrained at all times to prevent them from falling. Employers must also ensure that workers are provided with adequate training and supervision to handle glass safely.

### RISK CONTROLS

The use of specific measures to eliminate or minimise identified risks should involve the selection of the most effective control measures based on a risk assessment. The list of controls outlined below is not exhaustive and it is anticipated that a number of measures would need to be selected and integrated into the system of work to ensure the highest possible level of safety.

Consider the following control measures:

- store glass sheets on a 90° A-frame (accepted industry practice)
- store crates upright or on a 90° A-frame, with appropriate chock wedging – eg hardwood timber – to prevent the crate over balancing

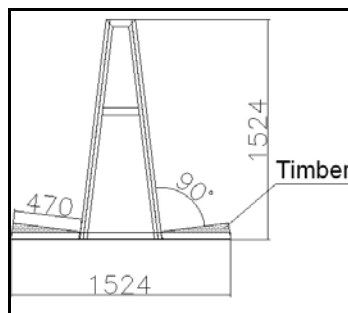

- don't exceed the safe working load of the racking
- ensure that crates are unpacked by workers trained in the safe handling and unpacking of glass contents
- ensure that the ground where A-frames and crates are stored is even, strong and well maintained – eg ensure that the grounding is not affected by weather conditions
- ensure that the racking is stable, regularly inspected and of appropriate weight, shape and size to support crates and glass sheets

WorkCover. **Watching out for you.**

- ensure that there is space between the ground and the racking to allow crates and sheets of glass to be removed with mechanical lifting equipment
- ensure appropriate restraints with fasteners are used to store crates and sheets of glass, and ensure that they are regularly inspected and allow sheets to be removed while simultaneously restraining other sheets (only remove one sheet or crate at a time)
- ensure the working area is safe before unpacking crates or sheets of glass
- ensure that the working area is well lit, passageways are clearly defined and mechanical lifting equipment operates safely without impeding pedestrians and other vehicles.

## FURTHER INFORMATION

Further information regarding the storage and handling of glass sheets can be found in the *Occupational Health and Safety Regulation 2001*.

Information is also available at [www.workcover.nsw.gov.au](http://www.workcover.nsw.gov.au) or from the WorkCover Assistance Service on 13 10 50.

## Disclaimer

This publication contains information regarding occupational health, safety, injury management or workers compensation. It includes some of your obligations under the various workers compensation and occupational health and safety legislation that WorkCover NSW administers. To ensure you comply with your legal obligations you must refer to the appropriate Acts.

This publication may refer to WorkCover NSW administered legislation that has been amended or repealed. When reading this publication you should always refer to the latest laws. Information on the latest laws can be checked at [www.legislation.nsw.gov.au](http://www.legislation.nsw.gov.au) or contact 1300 656 986.



**WorkCover NSW** 92 - 100 Donnison St Gosford NSW 2250  
Locked Bag 2906 Lisarow NSW 2252 WorkCover Assistance Service 13 10 50  
**Website** [www.workcover.nsw.gov.au](http://www.workcover.nsw.gov.au)  
Catalogue No 5346 © WorkCover NSW 0907

